

POWER MANAGEMENT

Low Power, 5V μ P Reset – Active LOW, Open-Drain Output

The IMP1811 supply voltage monitor is an improved, low-power replacement for the Dallas Semiconductor DS1811. Maximum supply current over temperature is a low 20 μ A, representing 50 percent lower power as compared to the DS1811.

The IMP1811 issues an active LOW reset signal whenever the monitored supply is out-of-tolerance. A precision reference and comparator circuit monitor power supply (V_{CC}) level. Tolerance level options are 5-, 10- and 15-percent. When an out-of-tolerance condition is detected, an internal power-fail signal is generated which forces an active LOW reset signal. After V_{CC} returns to an in-tolerance condition, the reset signal remains active for 150ms to allow the power supply and system microprocessor to stabilize.

The IMP1811 is designed with a open-drain output stage and operates over the extended industrial temperature range. Devices are available in compact surface mount SOT-23 packages and 3-lead TO-92 packages.

Other low power products in this family include the IMP1810/12/15/16/17, IMP1233D and IMP1233M.

Key Features

- ◆ Improved Dallas DS1811 replacement
 - 50% lower maximum supply current
- ◆ Low Supply Current
 - 20 μ A maximum (5.5V)
- ◆ Automatically restarts a microprocessor after power failure
- ◆ 150ms reset delay after V_{CC} returns to an in-tolerance condition
- ◆ Active LOW power-up reset
- ◆ Precision temperature-compensated voltage reference and comparator
- ◆ Eliminates external components
- ◆ Low-cost TO-92 package
- ◆ Compact surface mount SOT-23 package
- ◆ Operating temperature –40°C to +85°C

Family Selection Guide

Part	RESET Voltage (V)	RESET Time (ms)	Output Stage	RESET Polarity
IMP1810	4.620, 4.370, 4.120	150	Push-Pull	LOW
IMP1811	4.620, 4.350, 4.130	150	Open-Drain	LOW
IMP1812	4.620, 4.350, 4.130	150	Push-Pull	HIGH
IMP1815	3.060, 2.880, 2.550	150	Push-Pull	LOW
IMP1816	3.060, 2.880, 2.550	150	Open-Drain	LOW
IMP1817	3.060, 2.880, 2.550	150	Push-Pull	HIGH
IMP1233D	4.625, 4.375, 4.125	350	Open-Drain	LOW
IMP1233M	4.625, 4.375, 2.720	350	Open-Drain	LOW

Applications

- ◆ Set-top boxes
- ◆ Cellular phones
- ◆ PDAs
- ◆ Energy management systems
- ◆ Embedded control systems
- ◆ Printers
- ◆ Single board computers

Block Diagram

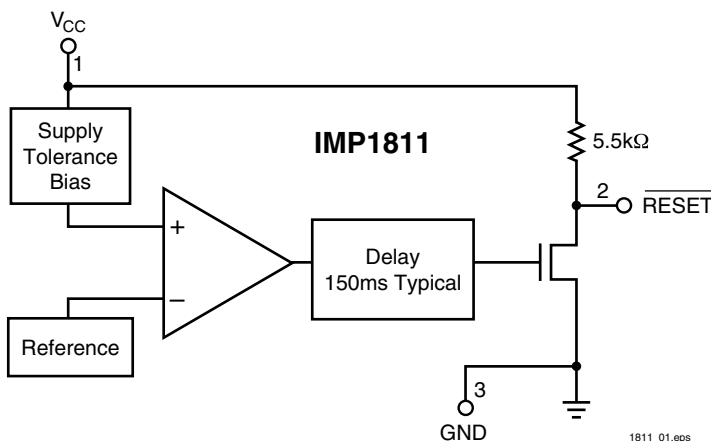

Typical Application

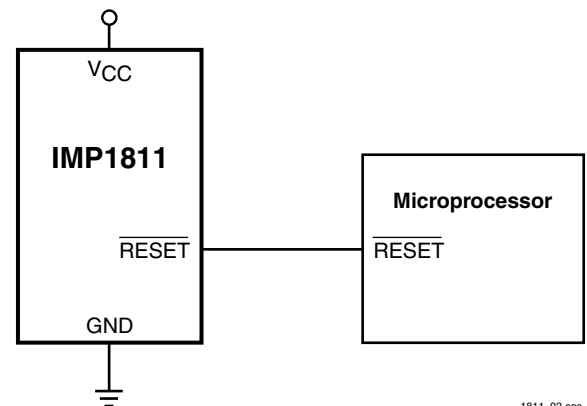

Pin Configuration

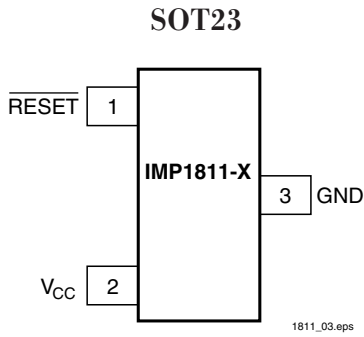

TO-92*

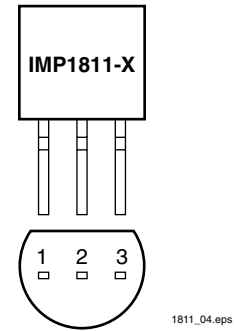

Pin Descriptions

Pin Number	Name	Function
1	RESET	Active LOW reset output
2	V _{CC}	Power supply input
3	GND	Ground

Package Marking Code

SOT-23 Package Letter Code			
A	B	Part	Reset Tolerance
C	A	IMP1811	5%
C	B	IMP1811	10%
C	C	IMP1811	15%

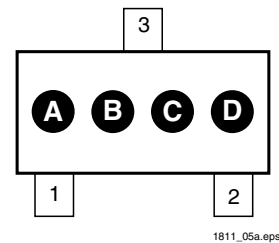

Ordering Information

Device Summary								Package Marking			
Part***	RESET Output Voltage (V)	RESET Tolerance (%)	RESET Time (ms)	Open-Drain** Output Stage	TO-92* Package	SOT-23 Package	RESET Polarity	A	B	C	D
IMP1811-5	4.62	5	150	●	●		LOW				
IMP1811-10	4.35	10	150	●	●		LOW				
IMP1811-15	4.13	15	150	●	●		LOW				
IMP1811R-5	4.62	5	150	●		●	LOW	C	A	X	X
IMP1811R-10	4.35	10	150	●		●	LOW	C	B	X	X
IMP1811R-15	4.13	15	150	●		●	LOW	C	C	X	X

* Add /S to Part Number for straight (unformed) leads. (ie. IMP18xx-x/S)

** Internal 5.5kΩ resistor pull up.

*** Add /T to Part Number for Tape and Reel. (ie. IMP18xx-x/T)

XX = Date code

Absolute Maximum Ratings

Voltage on V_{CC} -0.5V to 7V
 Voltage on $\overline{\text{RESET}}$ -0.5V to $V_{CC} + 0.5V$
 Operating Temperature Range -40°C to 85°C

Soldering Temperature 260°C for 10 seconds
 Storage Temperature -55°C to 125°C

*Voltages measured with respect to ground.
 These are stress ratings only and functional operation is not implied.*

Electrical Characteristics

Unless otherwise noted, $V_{CC} = 1.2V$ to $5.5V$ and specifications are over the operating temperature range of -40°C to +85°C.
 All voltages are referenced to ground.

Parameter	Symbol	Conditions	Min	Typ	Max	Units
Supply Voltage	V_{CC}		1.2		5.5	V
Output Voltage	V_{OH}	$I_{OUT} < 500\mu A$	$V_{CC} - 0.5V$	$V_{CC} - 0.1V$		V
Output Current	I_{OL}	Output = 0.4V, $V_{CC} \geq 2.7V$	+10			mA
Operating Current	I_{CC}	$V_{CC} < 5.5V$, $\overline{\text{RESET}}$ output open		8	20	μA
V_{CC} Trip Point (IMP1811-5)	V_{CCTP}		4.50	4.62	4.75	V
V_{CC} Trip Point (IMP1811-10)	V_{CCTP}		4.25	4.35	4.49	V
V_{CC} Trip Point (IMP1811-15)	V_{CCTP}		4.00	4.13	4.24	V
Internal Pull-Up Resistor	R_P		3.5	5.5	7.5	k Ω
Output Capacitance	C_{OUT}				10	pF
RESET Active Time	t_{RESET}		100	150	250	ms
V_{CC} Detect to $\overline{\text{RESET}}$ Low	t_{RPD}			2	5	μs
V_{CC} Slew Rate (V_{CCTP} (MAX) to V_{CCTP} (MIN))	t_F		300			μs
V_{CC} Slew Rate (V_{CCTP} (MIN) to V_{CCTP} (MAX))	t_R		0			ns
V_{CC} Detect to $\overline{\text{RESET}}$ High	t_{RPU}	$t_r = 5\mu s$	100	150	300	ms

Notes 1. The t_F value is for reference in defining values for t_{RPD} and should not be considered a requirement for proper operation or use.

Application Information

Operation – Power Monitor

The IMP1811 detects out-of-tolerance power supply conditions. It resets a processor during power-up, power-down and issues a reset to the system processor when the monitored power supply voltage is below the reset threshold. When an out-of-tolerance V_{CC} voltage is detected, the $\overline{\text{RESET}}$ signal is asserted. On power-up, $\overline{\text{RESET}}$ is kept active (LOW) for approximately 150ms after the power supply voltage has reached the selected tolerance. This allows the power supply and microprocessor to stabilize before $\overline{\text{RESET}}$ is released.

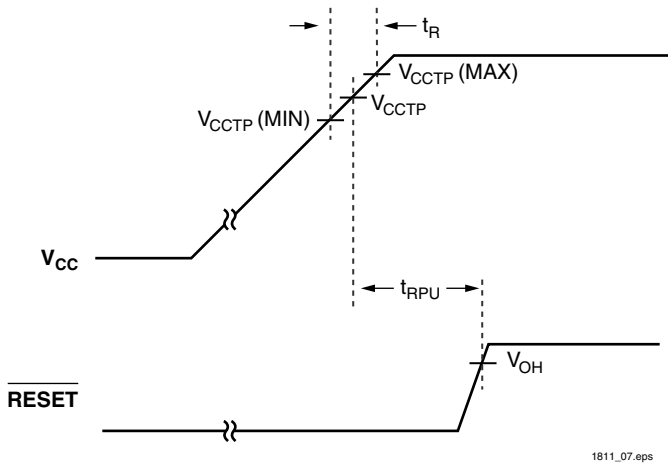

Figure 1. Timing Diagram: Power-Up

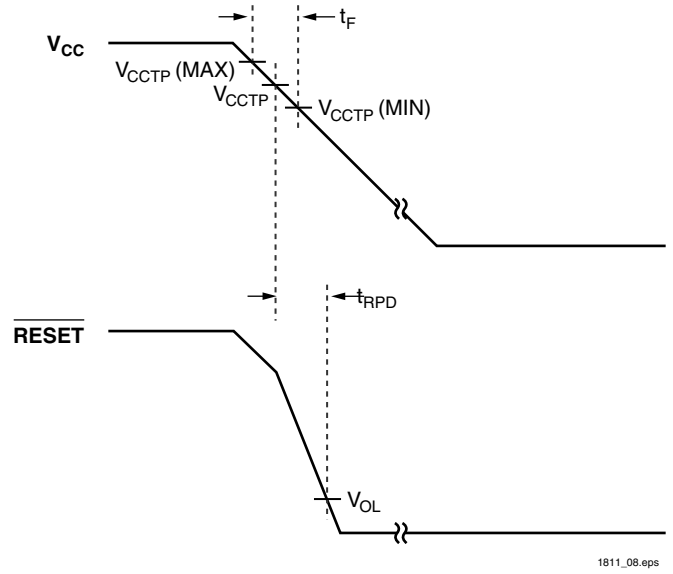
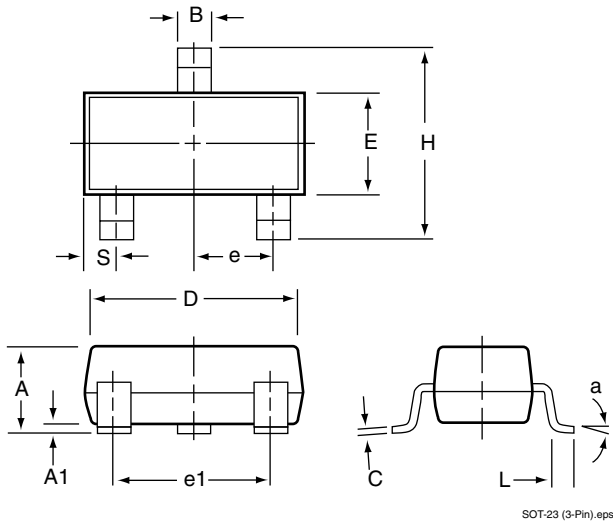

Figure 2. Timing Diagram: Power-Down

Package Dimensions

Plastic SOT-23 (3-Pin)



TO-92 (3-Pin)

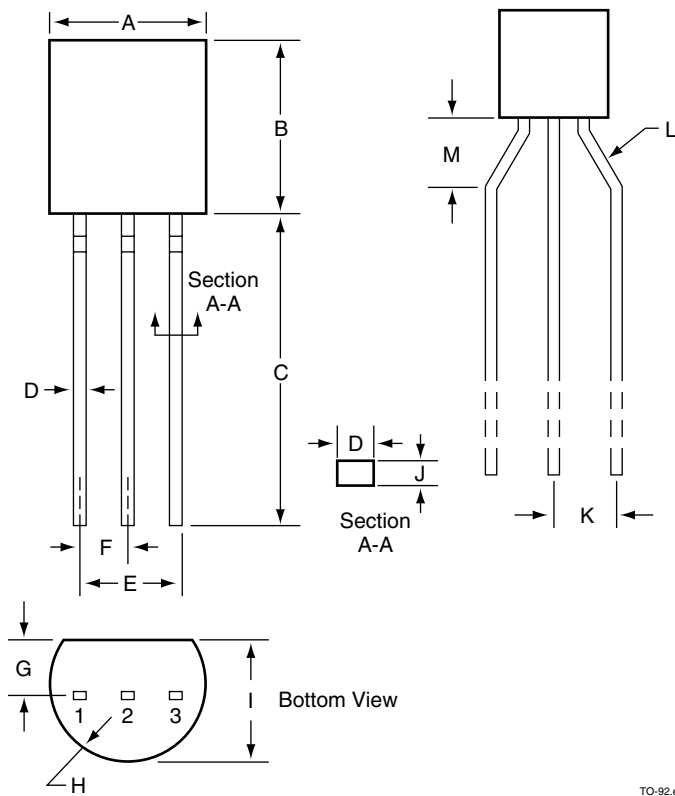

	Inches		Millimeters	
	Min	Max	Min	Max
Plastic SOT-23 (3-Pin)				
A	0.031	0.050	0.80	1.27
A1	0.004	0.010	0.10	0.25
B	0.015	0.020	0.37	0.51
C	0.003	0.007	0.085	0.18
D	0.110	0.120	2.80	3.04
E	0.047	0.055	1.20	1.40
e	0.035	0.040	0.89	1.03
e1	0.070	0.080	1.78	2.05
H	0.083	0.1039	2.10	2.64
L	0.027 REF		0.069 REF	
S	0.018	0.024	0.45	0.60
TO-92* (3-Pin)				
A	0.175	0.195	4.45	4.95
B	0.170	0.192	4.32	4.96
C	0.500	0.610	12.70	15.49
D	0.016	0.022	0.406	0.559
E	0.095	0.105	2.41	2.67
F	0.045	0.60	1.14	1.52
G	0.45	0.060	1.14	1.52
H	0.085	0.095	2.16	2.41
I	0.130	0.155	3.30	3.94
J	0.014	0.020	0.35	0.51
K	0.093	0.115	2.36	2.92
L	45°	60°	45°	60°
M	0.118 Typical		3.00	

* Formed leads are standard. Add /S to Part Number for straight leads.
(ie. IMP18xx-x/S)

1811_t04.eps



IMP, Inc.
Corporate Headquarters
2830 N. First Street
San Jose, CA 95134-2071
Tel: 408-432-9100
Tel: 800-438-3722
Fax: 408-434-0335
e-mail: info@impinc.com
<http://www.impweb.com>

The IMP logo is a registered trademark of IMP, Inc.
All other company and product names are trademarks of their respective owners.

© 1999 IMP, Inc.
Printed in USA
Publication #: 1004
Revision: A
Issue Date: 06/16/99
Type: Preliminary